

## Volumetric Compensation of machine tools with FIDIA numerical controls

Don't be satisfied with less!

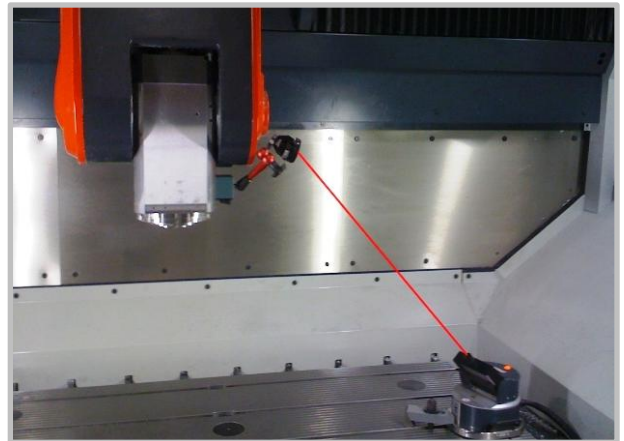
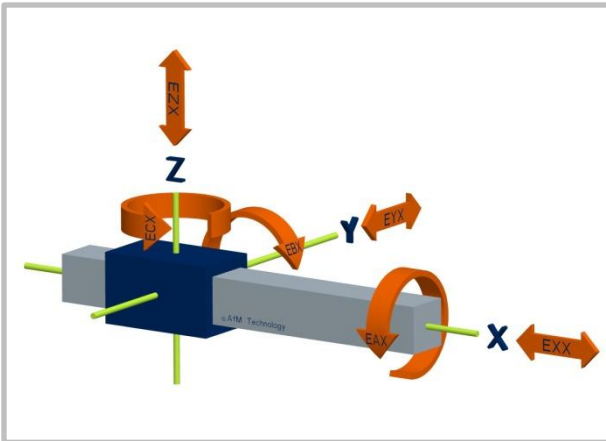

### Customers

Our customers are machine tool builders, CNC control producers, retrofit companies as well as users incorporating machine tooling in their production line.

### State-of-the-art

The accuracy of parts being produced is governed by the accuracy of the cartesian axes (X, Y, Z) of the machine tool.

The conventional methods used to establish machine tool deviations result in lengthy down time and therefore high costs. In most cases an additionally mechanical correction of the machine tool axes is necessary to resolve any deviations.

### Innovation

With LaserTRACER Systems we are measuring the volumetric deviation in the whole workspace of the machine tool. The evaluation will be given as a protocol with diagrams for each of the systematic deviations. Positioning, straightness, squareness, yaw pitch and roll errors will be completely measured.

The software-option **VAC (Volumetric Axes Compensation)** from company **FIDIA** allows a process correctionfile created by AfM to be entered directly into the FIDIA numerical control and from there it can be worked on online.

This results in a **noticeable improvement of the volumetric accuracy in the entire workspace of the machine tool.**

Hereby the complicated mechanical correction of the machine tool can often be avoided.

### Your Advantages

- Faster error mapping reduces down time and therefore costs.
- An increase of volumetric accuracy up to 85% through **VAC Compensation** in the FIDIA numerical control
- Usually no mechanical correction is necessary, also after collisions.
- Higher machine availability by Condition Monitoring

# Volumetric Compensation of machine tools



3D deviation without VAC compensation

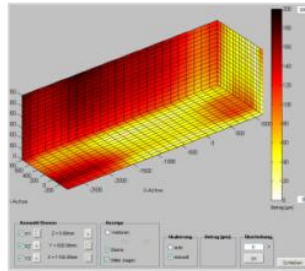

3D deviation with VAC compensation

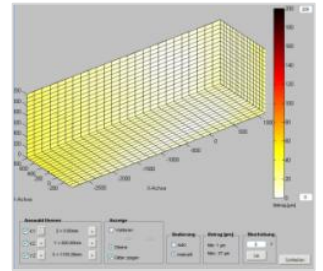

## Use of the most up to date laser technology

- Automated self-tracking laser interferometer with temperature stable construction.
- Highest accuracy through patented reference sphere.
- No complicated fine alignment on the machine tool.
- 4 – 6 measuring positions in the workspace of the machine tool for the evaluation of the complete volumetric deviation are required.
- Total time: approx. 4 - 6 hours
- Resolution: 0,001  $\mu\text{m}$
- Accuracy: 0,2  $\mu\text{m}$  + 0,3  $\mu\text{m}/\text{m}$
- Range: 0,2 m – 15 m  
(extendable by mathematical superposition)
- Principle: Multilateration

## Our Services

- Fast, cost-effective, volumetric machine tool analysis
- Visualisation of all existing machine errors
- Sale of VAC software option
- Creation of Compensation files
- Verification of the compensated machine tool
- Standard machine calibrations
- Mechanical service and repairs
- Training for LaserTRACER systems
- Sale of LaserTRACER systems and accessories

**AfM**  
Accuracy for Machines

**AfM Technology GmbH**  
Gartenstraße 133  
73430 Aalen  
Germany

Fon +49 (0) 73 61 88 96 08-0  
Fax +49 (0) 73 61 88 96 08-99  
www.afm-tec.de  
info@afm-tec.de

**FIDIA**